

# TYPICAL IN-BUILT MASONRY INSTALLATION

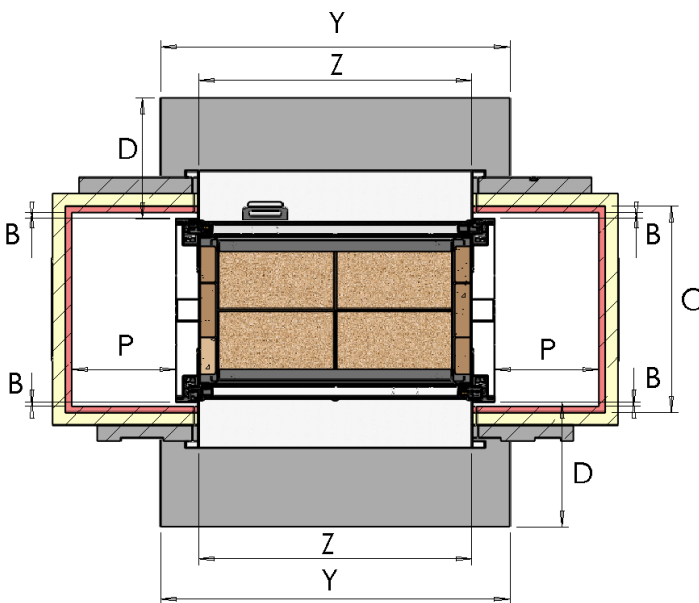
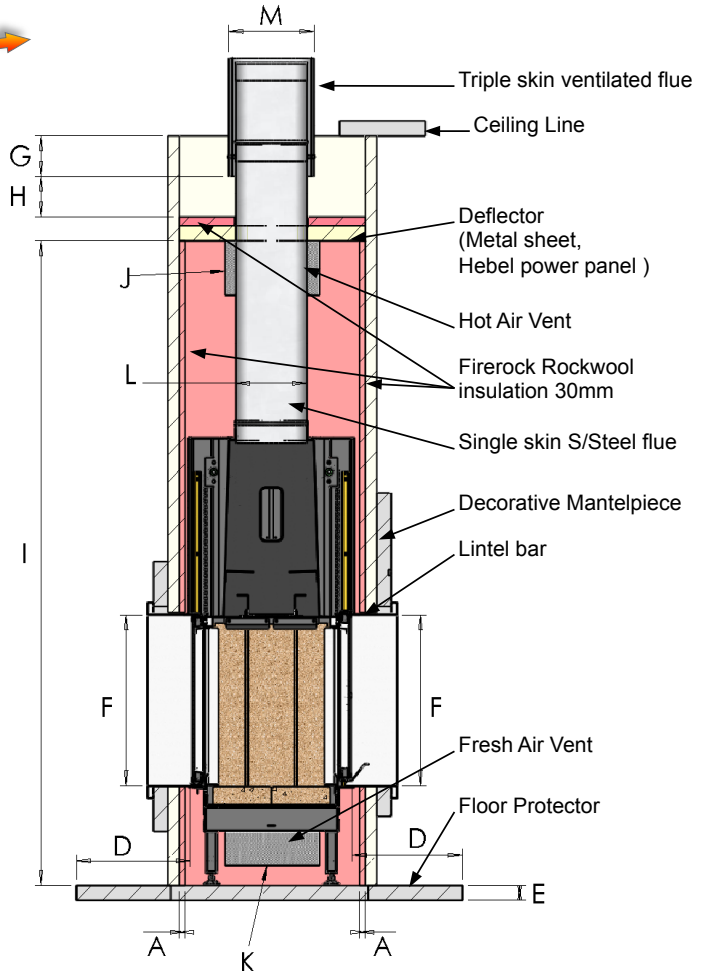
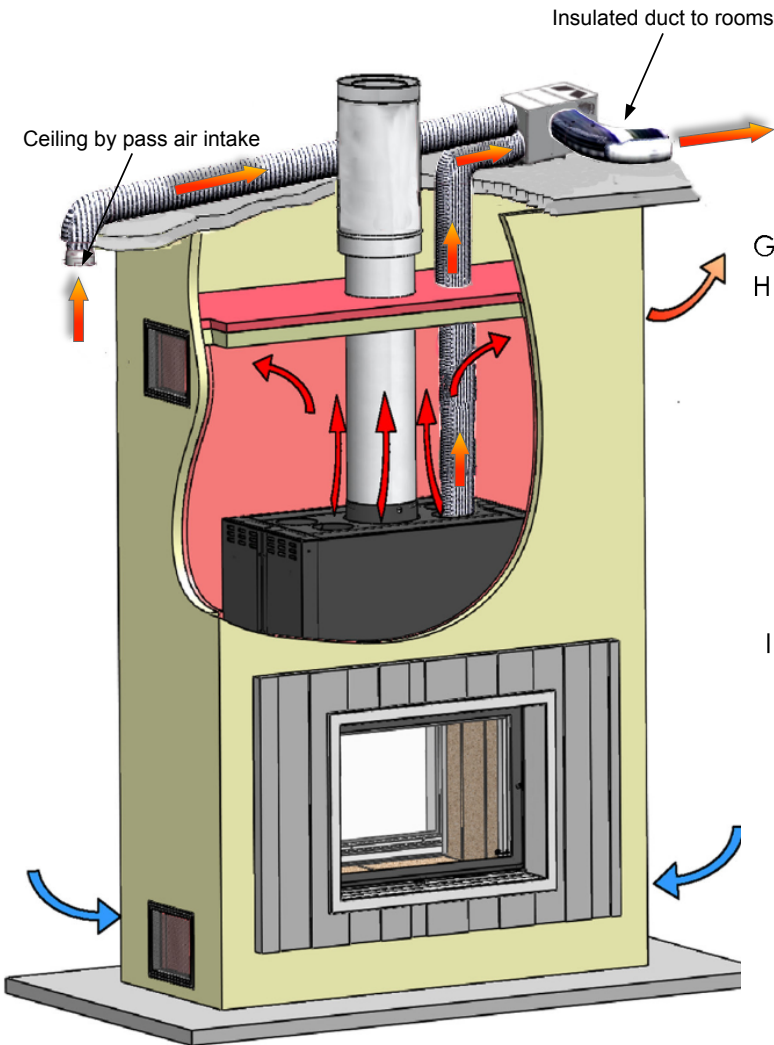

	CDF800L	CDF800R	DF1200
A	30	30	30
B*	3	3	3
C*	612	628	682
D*	600	600	600
E*	100	100	110
F*	590	590	580
G*	150	150	150
H*	150	150	150
I*	1800	1800	2400
J*	2X350 cm <sup>2</sup>	2X350 cm <sup>2</sup>	2X600 cm <sup>2</sup>
K*	2X350 cm <sup>2</sup>	2X350 cm <sup>2</sup>	2X600 cm <sup>2</sup>
L	ø 250	ø 250	ø 250
M	ø 350	ø 350	ø 350
P*	70	70	70
Y*	1100	1100	1500
Z	800	800	923

\* Minimum sizes

THE APPLIANCE AND FLUE-SYSTEM MUST BE INSTALLED IN ACCORDANCE WITH THE REQUIREMENTS OF AS/NZ 2918-2001 AND THE APPROPRIATE REQUIREMENTS OF THE RELEVANT BUILDING CODE OF AUSTRALIA .  
IN ALL CASES AS/NZS 2918 SHOULD BE REFERRED TO FOR CONFIRMATION OF ANY INSTALLATION REQUIREMENTS