

TYPICAL IN-BUILT MASONRY INSTALLATION

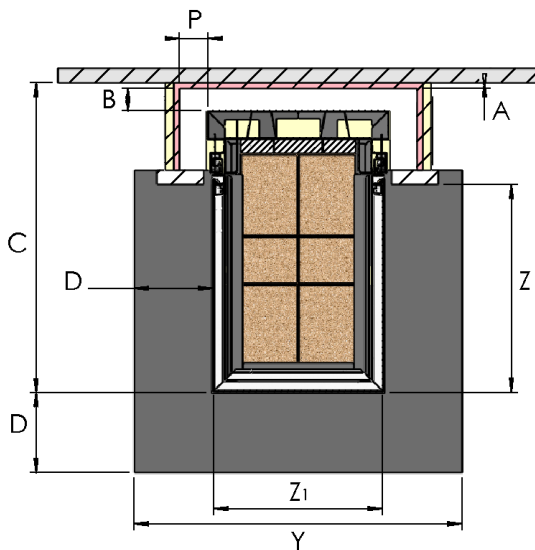
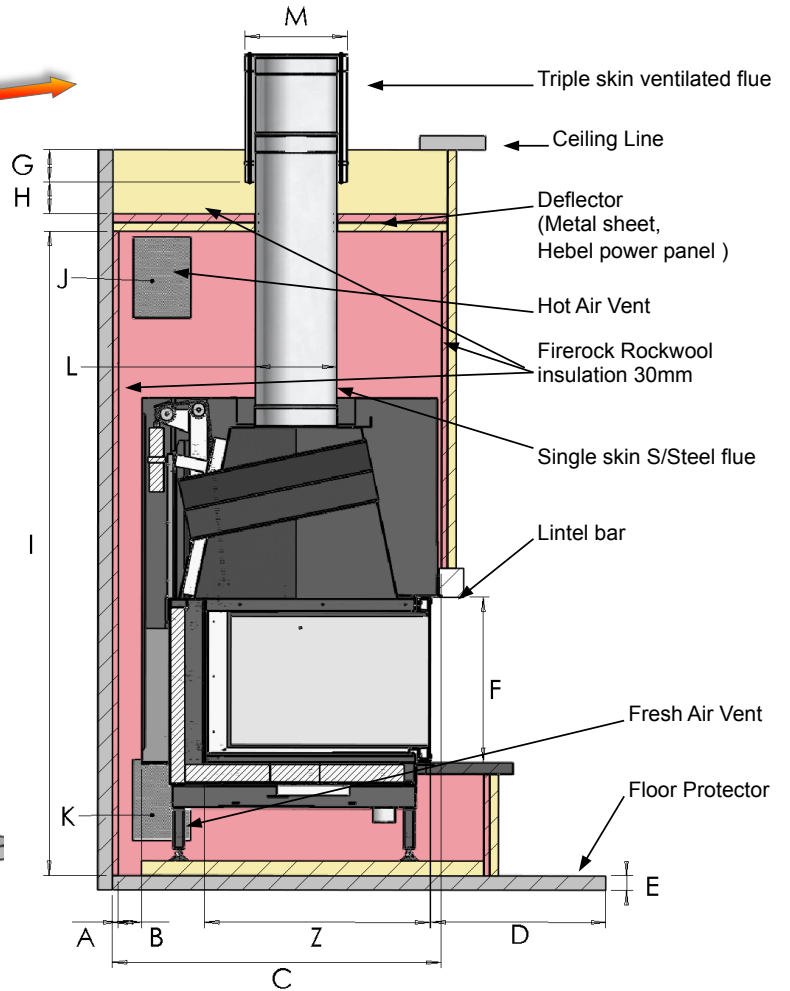
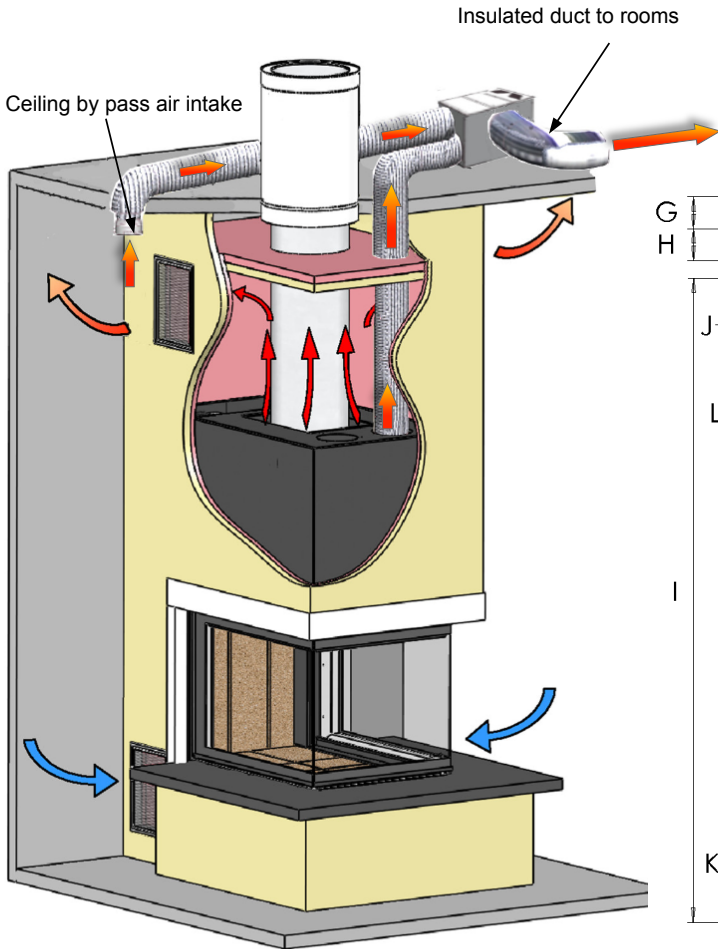

	D1000 EPI	D1000VAD	D1000VAG
A	30	30	30
B *	50	50	50
C *	1091	1003	1003
D *	500	500	500
E *	75	75	75
F *	595	590	590
G *	150	150	150
H *	150	150	150
I *	1800	1800	1800
J *	2x350cm ²	2x350cm ²	2x350cm ²
K *	2x350cm ²	2x350cm ²	2x350cm ²
L	250	250	250
M	350	350	350
P *	20	20	20
Y *	1643	1166	1166
Z *	990	900	900
Z1 *	643	666	666

* Minimum sizes

THE APPLIANCE AND FLUE-SYSTEM MUST BE INSTALLED IN ACCORDANCE WITH THE REQUIREMENTS OF AS/NZ 2918-2001 AND THE APPROPRIATE REQUIREMENTS OF THE RELEVANT BUILDING CODE OF AUSTRALIA .
IN ALL CASES AS/NZS 2918 SHOULD BE REFERRED TO FOR CONFIRMATION OF ANY INSTALLATION REQUIREMENTS